

MAXIM

MAX608 Evaluation Kit

Evaluates: MAX608

General Description

The MAX608 evaluation kit (EV kit) provides a regulated 5V or adjustable output voltage from an input source as low as 1.8V. It drives loads up to 0.5A with greater than 80% conversion efficiency.

This EV kit is a fully assembled and tested surface-mount circuit board. Additional pads on the bottom of the board accommodate the external feedback resistors for setting different output voltages.

Component List

DESIGNATION	QTY	DESCRIPTION
C1	1	68µF, 20V tantalum capacitor Sprague 593D686X0020E2W AVX TPSE686M020R0150
C2, C3	2	100µF, 16V tantalum capacitors Sprague 593D107X0016E2W AVX TPSE107M016R0100
C4, C5	2	0.1µF ceramic capacitors Vitramon VT1206Y104KXA
D1	1	3A, 40V Schottky diode Nihon NSQ03A04 Motorola MBRU340T3
L1	1	22µH inductor Sumida CDRH125-220
N1	1	N-channel MOSFET (SOT-223) Motorola MMFT3055EL
R1	1	0.050Ω, 1% resistor (SMT) Dale WSL-2010-R050-F IRC LR2010-01-R050-F
U1	1	Maxim MAX608ESA (SO-8)
JU1	1	3-pin header
None	1	Shunt
None	1	Printed circuit board
None	1	MAX608 data sheet

Features

- ◆ 5V or Adjustable Output Voltage
- ◆ 1.8V to V_{OUT} + 0.4V Input Range
- ◆ Up to 0.5A Output Current
- ◆ 5µA Max Shutdown Current
- ◆ 110µA Max Supply Current (MAX608 I.C. only)
- ◆ Up to 300kHz Switching Frequency
- ◆ 8-Pin SO, Surface-Mount Construction
- ◆ Fully Assembled and Tested

Ordering Information

PART	TEMP. RANGE	BOARD TYPE
MAX608EVKIT-SO	0°C to +70°C	Surface Mount

Component Suppliers

SUPPLIER	PHONE	FAX
AVX	(803) 946-0690	(803) 626-3123
Dale	(402) 564-3131	(402) 563-6418
IRC	(512) 992-7900	(512) 992-3377
Motorola	(602) 303-5454	(602) 994-6430
Nihon	(805) 867-2555	(805) 867-2698
Sprague	(603) 224-1961	(603) 224-1430
Sumida	(708) 956-0666	(708) 956-0702
Vishay/Vitramon	(203) 268-6261	(203) 452-5670



MAX608 Evaluation Kit

Quick Start

The MAX608 EV kit is a fully assembled and tested surface-mount printed circuit board. Follow the steps below to verify board operation. **Do not turn on the power supply until all connections are completed.**

- 1) Connect a 3V supply to the pad marked VIN. The ground connects to the GND pad.
- 2) Connect a voltmeter and load (if any) to the VOUT pad.
- 3) Place the shunt on JU1 across pins 1 and 2 for normal operation.
- 4) Turn on the power and verify that the output voltage is 5V.
- 5) Refer to the section *Evaluating Other Output Voltages* to modify the board for different output voltages.

Detailed Description

Jumper Selection

The 3-pin header JU1 selects shutdown mode. Table 1 lists the selectable jumper options.

Table 1. Jumper JU1 Functions

SHUNT LOCATION	SHDN PIN	MAX608 OUTPUT
2 & 3	Connected to VIN	Shutdown mode, $V_{OUT} = V_{IN} - 0.4V$
1 & 2	Connected to GND	MAX608 enabled, $V_{OUT} = 5.0V$

Inductor Selection

The 22 μ H Sumida CDRH125-220 inductor mounted on the EV kit board is a low-resistance, shielded, medium-current inductor. It provides excellent performance over the line and load ranges. Refer to the section *Determining the Inductor* in the MAX608 data sheet for instructions on selecting the inductor value.

Evaluating Other Output Voltages

The MAX608 is preset for a 5V output voltage. However, its output may also be adjusted via an external voltage divider formed by R2 and R3 (located on the bottom side of the board). The only other modification required is to cut the trace across R3. The section *Setting the Output Voltage* in the MAX608 data sheet gives instructions for calculating R2 and R3 values.

For output voltages greater than 15V, use the MAX1771.

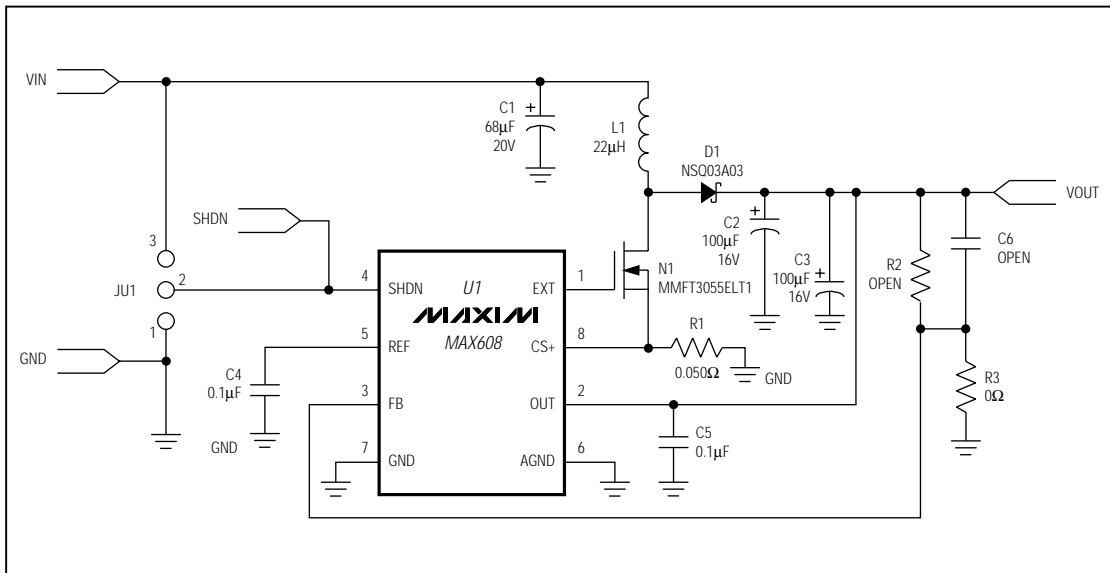

Figure 1. MAX608 EV Kit Schematic

MAX608 Evaluation Kit

Evaluates: MAX608

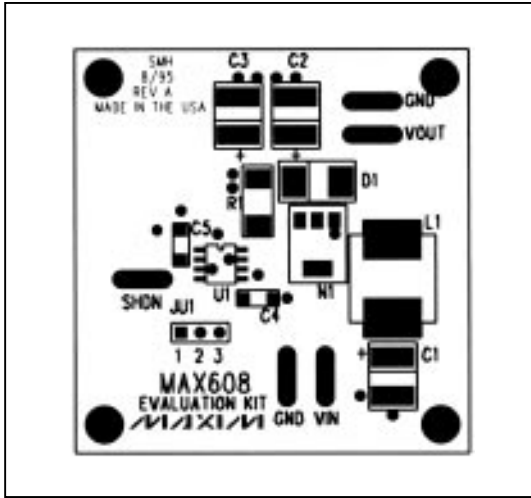

Figure 2. MAX608 EV Kit Component Placement Guide—Component Side

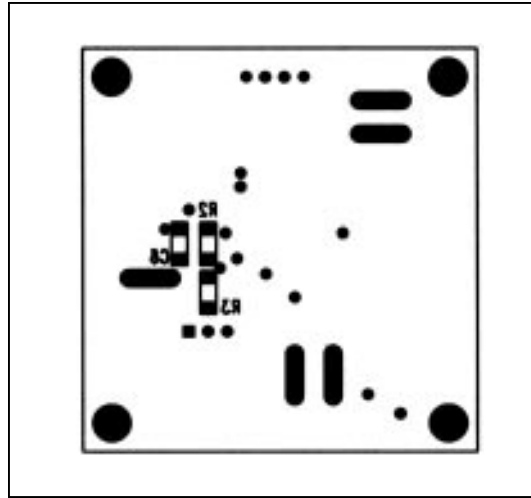

Figure 3. MAX608 EV Kit Component Placement Guide—Solder Side

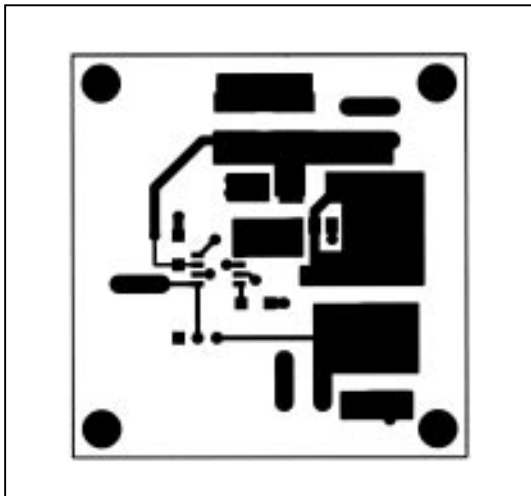

Figure 4. MAX608 EV Kit PC Board Layout—Component Side

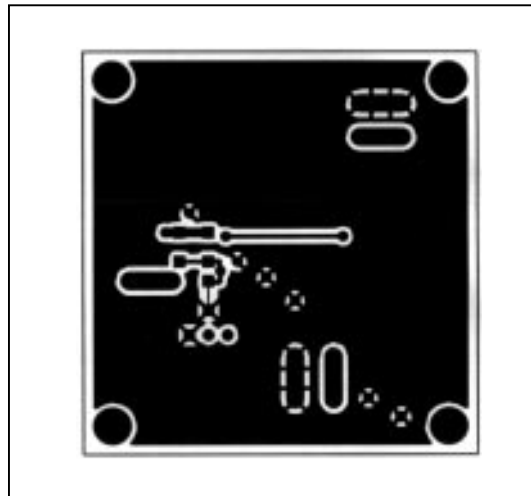

Figure 5. MAX608 EV Kit PC Board Layout—Solder Side

MAX608 Evaluation Kit

Evaluates: MAX608

Maxim cannot assume responsibility for use of any circuitry other than circuitry entirely embodied in a Maxim product. No circuit patent licenses are implied. Maxim reserves the right to change the circuitry and specifications without notice at any time.

4 _____ Maxim Integrated Products, 120 San Gabriel Drive, Sunnyvale, CA 94086 (408) 737-7600

© 1995 Maxim Integrated Products

Printed USA

MAXIM is a registered trademark of Maxim Integrated Products.